

ERHARD Diaphragm Valves, Weir Type "B" straight pattern, to DIN 3359-B1 or B3⁴⁾

of ductile cast iron or rubber-coated ductile cast iron

Range of application

Size DN	Pressure rating PN	Hydrost. test pressure ⁶⁾ in bars for		Max. adm. working pressure in bars at a working temperature of max. + 120 °C ⁵⁾
		body water	seat water	
15 - 150	10	17	11	10
200 - 250	6	12	6,6	6
300	4	6	4,4	4

When placing the order, please specify flow medium, working pressure, and working temperature. Specify if vacuum service is required.

Flanges B, DN 15 - 150, PN 16, GI, type 21, connecting dimensions and thickness to EN 1092-2¹⁾.
B, DN 200 - 300, PN 10, GI, type 21, connecting dimensions and thickness to EN 1092-2.

Materials/Equipment

Prod. No.	7300 0773	7300 1673
Body	Ductile cast iron EN-JS1030 ⁷⁾	Ductile cast iron EN-JS1030 ⁷⁾ with hard-rubber coating
Bonnet	Ductile cast iron EN-JS1030 ⁷⁾	Ductile cast iron EN-JS1030 ⁷⁾
Diaphragm	Grade according to working conditions ²⁾	Grade according to working conditions ²⁾
Stem	Ferritic chrome steel	Ferritic chrome steel
Threaded bush	Brass	Brass
Connecting bolts	Steel	Steel
Handwheel	Cast iron	Cast iron
Corrosion protection	Prime coat: chlorine-free caoutchouc derivative with modified alkyd resin Additionally external: synthetic resin varnish, sky blue, RAL 5015	

Features

Straight pattern, without stuffing-box, absolutely leaktight, with rising stem and non-rising handwheel. The valve is closed by turning the handwheel in clockwise direction. The travel stop is also serving as indicating device. Provided with grease nipple for lubrication of threaded bush and stem. Diaphragm can be replaced without removing the valve from the pipeline.

Dimensions

Size DN	Face-to-face dimension L ⁸⁾ mm	Height (approx.) H mm	Flange dia. D mm	Handwheel dia. d mm	Weight ³⁾ approx. kg
15	130	110	95	120	2,5
20	150	110	105	120	3,0
25	160	115	115	120	3,0
32	180	145	140	120	6,5
40	200	145	150	120	7,0
50	230	175	165	140	11
65	290	215	185	160	16
80	310	250	200	200	22
100	350	310	220	250	33
125	400	370	250	320	50
150	480	410	285	400	72
200	600	560	340	500	150
250	730	690	395	500	205
300	850	780	445	630	295

When Diaphragm Valves in hot water plants are subject to temperature changes at long intervals, the user has to reckon with slacking of the elastomer diaphragm where it is clamped between body and bonnet. Retensioning of the bonnet bolts could become necessary. If such plants are equipped with insulation against loss of heat, we recommend to install ERHARD ECLS Butterfly Valves.

Warning note: When using flow media endangering the environment and detrimental to health, pay attention to the relevant legal rules and regulations as well as to the regulations for prevention of accidents, AD prints, DVGW regulations, and similar. Moreover, valve design with safety sealing device, e. g. Prod. No. 7300 0772, has to be chosen for such media, so that the medium cannot penetrate to the outside when the diaphragm breaks.

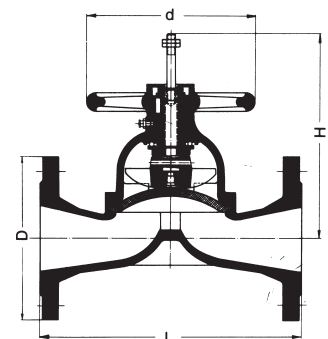

- ¹⁾ For DN 80 please specify if the flanges are to be drilled with 4 or 8 holes.
- ²⁾ Diaphragm grade according to working pressure, flow medium, and working temperature.
- ³⁾ Net weights (without obligation).
- ⁴⁾ Only PN 10 to DIN 3359.
- ⁵⁾ Rubber-coated valves up to max. + 110 °C according to diaphragm grade.
- ⁶⁾ According EN 12266 and 1074
- ⁷⁾ Corresponding to former DIN description 0.7040 (GGG-40).
- ⁸⁾ According EN 558, FTF, basic serie 1